

RigExpert

# MATCH

Your Upgradeable Antenna  
and Cable Analyzer



# USER MANUAL

Introduction .....	3
Device overview .....	3
Technical specifications .....	4
Getting started .....	4
Unpacking and inspection .....	4
First-time use .....	4
Main menu .....	4
Quick access with Hot Keys .....	4
Multifunctional keys .....	4
Basic operation .....	4
Measurement functions .....	5
Practical applications and examples .....	6
Coaxial lines .....	6
Understanding upgradeability .....	9
Upgrades and enhanced features .....	9
Upgrades overview .....	9
Where to buy a License Pack .....	9
Step-by-step instructions for upgrading your MATCH analyzer .....	9
Maintenance and care .....	11
RigExpert warranty .....	12
Annex 1 Licenses comparison table .....	12
Annex 2 Precautions .....	12
Annex 3 Tools menu .....	12
Annex 4 Settings menu .....	14
Annex 5 TDR mode (available for RFE license) .....	14
Annex 6 Calibration .....	15
Annex 7 Dummy loads .....	16
Contact information .....	16

Thank you for choosing the RigExpert MATCH antenna and cable analyzer — a state-of-the-art solution designed to meet the diverse needs of modern radio professionals and enthusiasts. Engineered to be powerful yet intuitive, MATCH is more than just a tool; it's a versatile companion built to grow with you.

With an innovative upgradeable architecture, MATCH ensures you stay ahead in the ever-evolving field of radio frequency (RF) technology.

Capable of measuring SWR (standing wave ratio), return loss, cable loss, and other critical parameters in the range of 100 kHz to 70 MHz in the Base model (initial setup functionality in every MATCH device), MATCH can be enhanced with licenses to expand frequency up to 230 MHz with the Advance license and 500 MHz with the RFE\* license and added features with each upgrade. (See «Understanding upgradeability» page 9).

### The RigExpert MATCH makes the following tasks effortless:

- Rapidly checking antennas to ensure optimal performance.
- Tuning antennas to resonance with precision.
- Comparing antenna characteristics before and after significant events like storms or heavy rainfall.
- Creating and measuring coaxial stubs with ease.
- Esting cables for faults, measuring cable loss, and determining characteristic impedance.
- Measuring capacitance or inductance of reactive loads.

Whether you are installing new antenna systems, diagnosing cable issues, or fine-tuning equipment for peak performance, RigExpert MATCH is equipped to handle it all. Its robust construction, advanced technology, and user-friendly design make it an essential tool for anyone serious about RF analysis.

MATCH is a future-proof device that evolves to meet your growing demands.

RigExpert® MATCH Upgradeable powerful antenna and cable analyzer up to 500 MHz with a big display.

### Applications:

- Amateur radio;
- Professional radio;
- Commercial radio;
- Telecommunications.

### Use cases:

- Checking and adjusting antennas;
- Cable length and velocity factor measurements;
- 1/4- $\lambda$ , 1/2- $\lambda$  coaxial stubs setup;
- Finding cable fault;
- Measurement of parameters of other RF elements - capacitors and inductors.
- Transformers;
- Traps.

### Main Features:

- Big color TFT LCD 4.0" display;
- High contrast with low power consumption;
- Consistency and accuracy without prior recalibration;
- Multilingual user-friendly interface;
- Built-in Helper at the push of a button;
- Factory calibration - ready to use;
- OSL calibration data memory to select different measurement fixtures quickly.



\* RFE - Radio Field Engineer

The frequency range is 0.1 MHz to 70 MHz, and with an Advance license, it can be upgraded up to 230 MHz and up to 500 MHz with RFE license.

**Frequency entry:** 1 kHz resolution.

**Output impedance:** 50 Ohm.

**Directivity:** 43db (calibrated).

**SWR measurement range:**

- 1 to 100 in numerical modes;
- 1 to 10 in chart modes.

**SWR system impedance:** selectable 25, 50, 75, 100, 150, 200, 300, 450, 600;

**Display modes:**

- SWR at single or multiple frequencies;
- SWR, return loss, R, X, Z, L, C at a single frequency;
- SWR chart;
- R, X chart;
- Smith chart (available for Advanced, RFE licenses);
- Return loss chart;
- Time Domain Reflectometry (TDR) chart (available for RFE license);
- Tools (available for Base model): self-test.
- Advanced tools (available for Advanced, RFE licenses): stub tuner, length & velocity factor, cable loss, and characteristic impedance measurement.
- Advanced tools (available for RFE license): LC meter.
- OSL calibration (available for Advanced, RFE licenses): Yes.
- Factory OSL: Yes.
- User OSL (available for RFE licenses): 10 profiles available.
- Records: 250 unified memory slots.
- Setting up the screen palette, volume, language, and units of measurement.

**RF output:**

- Connector type: N.
- Output signal shape: square.
- Output power: -10 dBm (at 50 Ohm load).

**Power:**

- One Li-Ion battery ICR18650, 2600mAh.
- Max. 2 hours 40 minutes of continuous measurement.
- Tree power modes with activities control and auto power off.
- When the analyzer is connected to a DC adapter or a PC (VNA is off-mode) with a USB socket, it takes power from these sources.

**Interface:**

- 480x480 color TFT 4.0" LCD display.
- Water-proof keypad.
- Multilingual menus and Help screens
- USB Type-C connection to a personal computer.
- Bluetooth specification v.4.2, LE (available for Advanced, RFE licenses).

**Dimensions:** 93 × 207 × 37 mm (3.7 × 8.1 × 1.5 in).

**Operating temperature:** -10...60 °C (14...140 °F).

**Weight:** 363g (12,8 oz).

**Warranty:** 2 years.

### Unpacking and Inspection

Ensure all accessories are included: MATCH analyzer, USB cable, carrying case, and RigExpert Club card. Report any damage immediately to your distributor.

### First-Time Use

Press the  key located at the bottom-right corner of the keypad to turn on the analyzer. After displaying the initial message (showing a firmware version and a device serial number, actual of the instrument), a Main menu appears on the screen.

*The MATCH analyzer can be charged using a charger or via a USB port on your computer (while the device is powered off) with a standard USB Type-C cable.*

*The device is not charged from the PC during measurements.*



*The analyzer will be turned off automatically if not in use for too long.*

### Main menu

The Main menu serves as the central hub for accessing the various features and functions of your RigExpert MATCH analyzer. From here, you can easily navigate to perform measurements, configure settings, and explore advanced tools.

Use  and  keys to scroll through the menu, then press  to select an item.

### Quick access with Hot Keys

You may use Hot keys for quick access to certain tasks. Follow the prompts on the device keyboard. To call up prompts while using the device, use the Help menu by pressing  key. For instance, press  (the SWR chart) key to open the SWR chart screen immediately.

### Multifunctional keys

Most keys on the analyzer's keypad perform several functions.

For instance, numbers (1) are used to enter frequency and other numerical parameters.

Main functions (2) provide quick access to most common tasks.

Alternative functions (3) are executed if the user holds the  (Functional) key.

For convenience, alternative functions are marked with orange color.

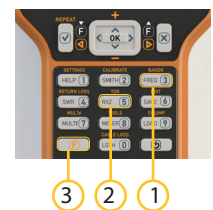

## Basic Operation

### Connecting to your antenna

Ensure all accessories are included: MATCH analyzer, USB cable, carrying case, and RigExpert Club card.

Report any damage immediately to your distributor.

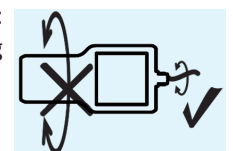

## Measurement functions

### (Base model)

**SWR Chart:** Once your antenna is connected to the analyzer, it is time to measure its characteristics.

Press **(4)** (the SWR chart) key to open the SWR chart screen, then press **(OK)** to start a new measurement or press **(✓)** for running a continuous sweep.

A few moments later, the result will be displayed on the analyzer's screen. Below the chart, you will see on the right the values measured at the marker point on the right of the screen, the point with the minimal value of range is on the left of the screen.

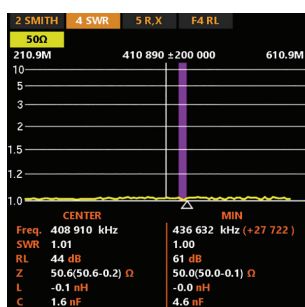

These values are for series as well as parallel models of the impedance of a load.

You can quickly set up a chart for yourself using the following keys:

- (3)** - set frequency and range
- (◀)** and **(▶)** keys - change frequency
- (▲)** and **(▼)** keys - change range
- (F)** + **(◀)** **(▶)** - jump to minimal value of SWR
- (F)** + **(▲)** **(▼)** - change scale
- (6)** - save the chart or **(9)** - load data
- (F)** + **(6)** - edit memory name
- (F)** + **(0)** - select band
- (F)** + **(1)** - HOLD reference
- (F)** + **(OK)** - HOLD last
- (F)** + **(X)** - reset HOLD

Use the Help menu by pressing the **(1)** key.

### Chart ZOOM

Use the arrow keys to increase or decrease the center frequency or the scanning range. Watch the chart zooming in or out, or changing its position. Use the **(F)** and **(▲)** or **(▼)** key combination to zoom the vertical scale of the chart.

Do not forget to press the **(OK)** key for the new measurement to start.

Press **(F)** and **(3)** to quickly choose a radio amateur band.

Switch between the Smith chart, SWR chart, R, X chart, and RL charts for one measurement using keys

**(2), (4), (5), (F) + (4)**

### Frequency and range entry

To enter the center frequency or the sweep range, press **(3)** the **(Frequency, Range)** key.

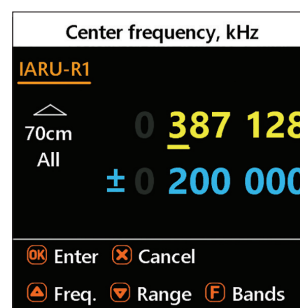

Use the cursor keys to navigate, or the **(0)** to **(9)** keys to enter values, and press the **(OK)** key to apply.

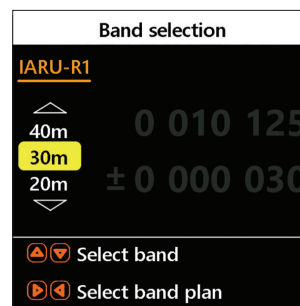

### Return loss chart

The return loss (RL) chart, which is very similar to the SWR chart, is activated by pressing the **(F)** and **(4)** (RL chart) key combination or choosing in the Main menu.

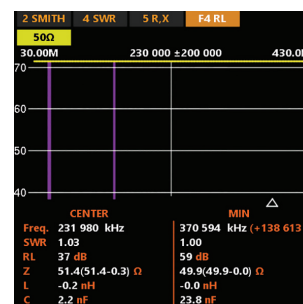

You can quickly set up a chart for yourself using the same keys as in the SWR chart.

### R, X chart

Press the **(5)** (RXZ) key in the Main menu to access the R, X chart mode. Positive values of reactance (X) correspond to inductive load, while negative values correspond to capacitive load.

The chart will display R and X for series or parallel models of a load. Press **(F)** and **(1)** to switch between these models.

In the series model, impedance is expressed as resistance and reactance connected in series.

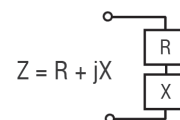

In the parallel model, impedance is expressed as resistance and reactance connected in parallel.

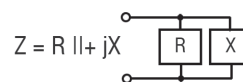

The marker at the bottom of the screen shows a resonant frequency closest to the center of the scan.

You can quickly set up a chart for yourself using the same keys as in the SWR chart.

## Smith chart (available for Advanced and RFE licenses)

The **2** (Smith) key opens a screen where the reflection coefficient is plotted on the Smith chart.

For a list of Hot keys, press the **1** (Help) key, as usual.

A small marker is used to indicate the center frequency.

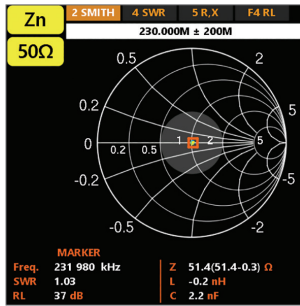

## Memory operation

The device has 250 unified slots for storing your records. Record operations are linked to relevant data screens - SWR, RX, RL, and Smith charts mark their records with a 'Z' slot identifier, and TDR chart marks with a 'T' identifier.

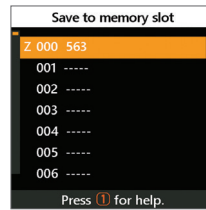

Use **6**, **9**, **F** or **9** and respectively for Load, Save, or Edit Name operations in relevant data screens.

## SWR meter, SWR2Air

This mode allows one to measure SWR at one frequency. Mode provides analog meter or historical trend view and has SWR2Air possibility. Change frequency with **4**, **6**, **3** buttons. Press the **OK** key to start or stop the measurement, and **F** + **OK** starts the measurement with the SWR2Air function.

SWR2Air can manifest measured values by speaker or radio(air), using the same measured antenna. Measuring is coded in Morse code, values in the range 1.0-4.9 come as two-digit words without dots, and values 5.0 and above are represented as long dashes. Portable, FM-able radio is typically used to pick up radio channels. Change transmit frequency by pressing **F** + **3**, other SWR2Air-related parameters you can find in the Setup menu. Use **F** and **7** to switch between meter and trend view (Logger).

## MultiSWR mode

Press the **7** key to see the SWR at up to five different frequencies. This mode may be useful for tuning multi-band antennas.

SWR	MultiSWR
50Ω	
14 175 kHz	1.02
18 118 kHz	1.02
21 225 kHz	1.02
24 940 kHz	1.02
28 850 kHz	1.02

**OK** - start/stop, **1** - help.

Use the **4** and **7** cursor keys to select a frequency to be set or changed, then xpress the **3** (Frequency) key to enter a new value. Do not forget to press the **OK** key to start the measurement.

## HOLD functions

These functions are accessible in SWR, RL, and Smith charts. You can keep some measuring results on the screen next to fresh measuring results. There are two ways of using HOLD.

Using **F** + **1** keys allows you to make the current curve as a reference curve (you can even use the RECORD curve). The reference curve will be retained until the next arbitrary user action.

Using **F** + **OK** enables HOLD last operation. New measurements will be shown with the previous curve. The text mark "ref" or "last" indicates the current mode of HOLD functionality.

Using **F** + **1** for canceling HOLD mode.

## Practical applications and examples

### Checking the antenna

It is a good idea to check an antenna before connecting it to the receiving or transmitting equipment. The SWR chart mode is good for this purpose.

Also you can use **Multé** tool located in Main menu. Multé will check your rig against all HAM bands defined in your region and rate all bands where SWR lower than 3.0 in range of 1...5 stars. Select band for detailed evaluation and press **3** to run SWR chart for this band.

### Adjusting the antenna

When the measurement diagnoses that the antenna is off the desired frequency, the analyzer can help in adjusting The physical dimensions of a simple antenna (such as a dipole) can be adjusted knowing the actual resonant frequency and the desired one. Other types of antennas may contain more than one element to adjust (including coils, filters, etc.), so this method will not work. Instead, you may use the **SWR mode** or the **Smith chart mode** to continuously see the results while adjusting various parameters of the antenna.

For multi-band antennas, use the **MultiSWR mode**. You can easily see how changing one of the adjustment elements (trimming capacitor, coil, or physical length of an aerial) affects SWR at up to five different frequencies.

## Coaxial lines

### Open- and short-circuited cables

The pictures show **R** and **X** charts for a piece of cable with open- and short-circuited far ends. A resonant frequency is a point at which X (reactance) equals to zero:

- In the open-circuited case, resonant frequencies correspond to (left to right) 1/4, 3/4, 5/4, etc. of the wavelength in this cable;
- For the short-circuited cable, these points are located at 1/2, 1, 3/2, etc. of the wavelength.

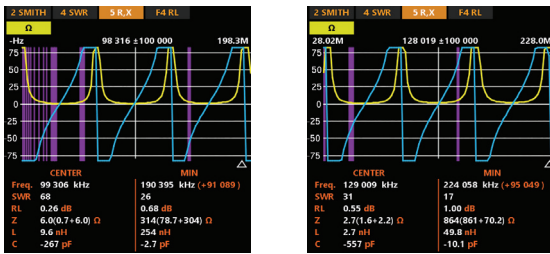

### Cable length measurement

The resonant frequencies of a cable depend on its length as well as on the velocity factor.

A velocity factor is a parameter that characterizes the slowdown of the speed of the wave in the cable compared to a vacuum. The speed of the wave (or light) in a vacuum is known as the electromagnetic constant: **c=299,792,458 meters** (or **983,571,056 feet**) per second.

Each type of cable has a different velocity factor: for instance, for HyperFlex 10/.400" it is 0.86. Notice that this parameter may vary depending on the manufacturing process and materials the cable is made of.

To measure the physical length of a cable,

1. Locate a resonant frequency by using the **R, X** chart.

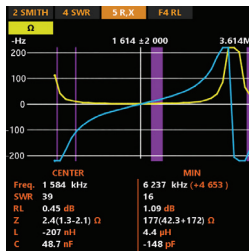

2. Knowing the electromagnetic constant and velocity factor of the particular type of cable, find the speed of electromagnetic wave in this cable.

Example:

The 1/4 - wave resonant frequency of a piece of open-circuited RG-58 cable is 4370 kHz

$$299,792,458 * 0.86 = 257,821,513.88 \text{ meters per second}$$

- or -

$$983,571,056 * 0.86 = 845,871,108.16 \text{ feet per second}$$

3. Calculate the physical length of the cable by dividing the above speed by the resonant frequency (in Hz) and multiplying the result by the number which corresponds to the location of this resonant frequency (1/4, 1/2, 3/4, 1, 5/4, etc).

$$257,821,513.88 / 1,584,000 * (1/4) = 40 \text{ meters}$$

- or -

$$845,871,108.16 / 1,584,000 * (1/4) = 134 \text{ feet}$$

### Velocity factor measurement

For a known resonant frequency and physical length of a cable, the actual value of the velocity factor can be easily measured:

1. Locate a resonant frequency as described above.

Example:

5 meters (16.4 feet) of open-circuited cable. Resonant frequency is 9400 kHz at the 1/4-wave point.

2. Calculate the speed of electromagnetic wave in this cable. Divide the length by 1/4, 1/2, 3/4, etc. (depending on the location of the resonant frequency), then multiply by the resonant frequency (in Hz).

$$5 / (1/4) * 9,400,000 = 188,000,000 \text{ meters per second}$$

- or -

$$16.4 / (1/4) * 9,400,000 = 616,640,000 \text{ feet per second}$$

3. Finally, find the velocity factor. Just divide the above speed by the electromagnetic constant.

$$188,000,000 / 299,792,458 = 0.63$$

- or -

$$616,640,000 / 983,571,056 = 0.63$$

### Cable fault location

To locate the position of a probable fault in a cable, just use the same method as when measuring its length. Watch the behavior of the reactive component (X) near the zero frequency:

*If the value of X is moving from  $-\infty$  to 0, the cable is open-circuited:*

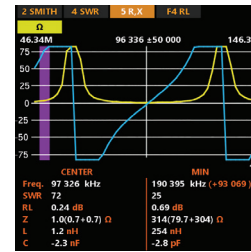

*If the value of X is moving from 0 to  $+\infty$ , the cable is short-circuited:*

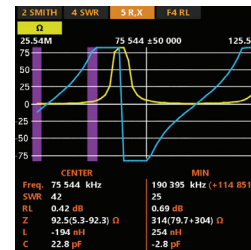

### Making 1/4-λ, 1/2-λ, and other coaxial stubs

Pieces of cable of certain electrical length are often used as components of baluns (balancing units), transmission line transformers or delay lines. To make a stub of the predetermined electrical length

1. Calculate the physical length. Divide the electromagnetic constant by the required frequency (in Hz). Multiply the result by the velocity factor of the cable, then multiply by the desired ratio (in respect to λ).
2. Cut a piece of cable slightly longer than this value. Connect it to the analyzer. The cable must be open-circuited at the far end for 1/4-λ, 3/4-λ, etc. stubs, and short-circuited for 1/2-λ, λ, 3/2-λ, etc. ones.
3. Set the frequency the stub is designed for.
4. Cut little pieces (1/10 to 1/5 of the margin) from the far end of the cable until the X value falls to zero (or changes its sign). Do not forget to restore the open circuit, if needed.

Example:

$1/4\text{-}\lambda$  stub for 28.2 MHz, cable is RG-58 (velocity factor is 0.66)

$$299,792,458 / 28,200,000 \times 0.66 \times (1/4) = 1.75 \text{ meters}$$

- or -

$$983,571,056 / 28,200,000 \times 0.66 \times (1/4) = 5.75 \text{ feet}$$

A piece of 1.85 m (6.07 ft) was cut.

The margin is 10 cm (0.33 ft).

The cable is open-circuited at the far end.

28,200 kHz was set.

11 cm (0.36 ft) were cut off.

## Measuring the characteristic impedance

The characteristic impedance is one of the main parameters of any coaxial cable. Usually, its value is printed on the cable by the manufacturer. However, in certain cases, the exact value of the characteristic impedance is unknown or is in question. To measure the characteristic impedance of a cable

1. Connect a non-inductive resistor to the far end of the cable. The exact value of this resistor is not important. However, it is recommended to use 50 to 100 Ohm resistors.
2. Enter the R, X chart mode and make measurement in a reasonably large frequency range (for instance, 0 to 200 MHz).

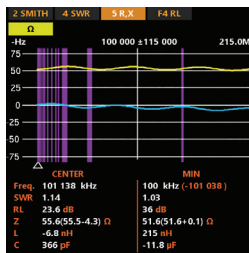

Example: Unknown cable with 50 Ohm resistor at the far end

3. Changing the display range and performing additional scans, find a frequency where R (resistance) reaches its maximum, and another frequency with minimum. At these points, X (reactance) will cross the zero line
4. Use the cursor and find values of R at previously found frequencies.

5. Calculate the square root of the product of these two values.

48.7 Ohm - max

51.2 Ohm - min

$$\text{square root of } (48.7 \times 51.2) = 50 \text{ Ohm}$$

The Tools menu (see page 12) contains several automated tools for coaxial line calculations.

## Measurement of other elements

Although RigExpert MATCH is designed for use with antennas and antenna feeder paths, it may be successfully used to measure the parameters of other RF elements.

## Capacitors and inductors

The analyzer can measure capacitance from a few pF to about 0.1 μF as well as inductance from a few nH to about 100 μH. Since measuring capacitance and inductance is not the main purpose of RigExpert analyzers, the user will have to gain some experience in such measurements. Be sure to place the capacitor or the inductor as close as possible to the RF connector of the analyzer.

1. Enter the and R, X chart modes and select a reasonably large scanning range. Perform a scan.

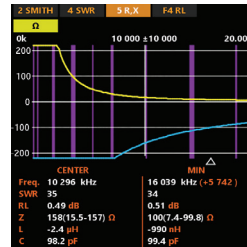

Example 1:

Unknown capacitor

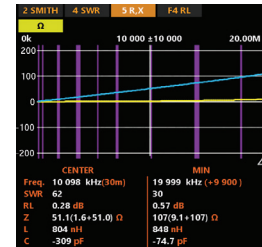

Example 2:

Unknown inductor

2. By using left and right arrow keys, scroll to the frequency where X is -25...-100 Ohm for capacitors or 25...100 Ohm for inductors. Change the scanning range and perform additional scans, if needed

## Transformers

RigExpert analyzers can also be used for checking RF transformers. Connect a 50-ohm resistor to the secondary coil (for 1:1 transformers) and use SWR chart, R, X chart, or Smith chart modes to check the frequency response of the transformer. Similarly, use resistors with other values for non-1:1 transformers.

## Traps

A trap is usually a resonant L-C network used in multi-band antennas. By using a simple one-turn wire coil, the resonant frequency of a trap may be measured.

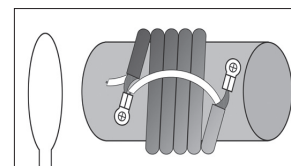

A coaxial trap constructed of 5 turns of TV cable (coil diameter is 6 cm) was measured

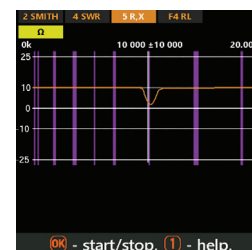

A one-turn coil (about 10 cm in diameter) connected to the analyzer was placed, co-axially, a few centimeters away from the measured trap.

The SWR chart shows a visible dip near 10.3 MHz, which is a resonant frequency of the trap.

## Understanding upgradeability

The RigExpert MATCH analyzer is designed with a unique upgradeable architecture, allowing it to evolve alongside your needs. This feature ensures that your investment remains relevant as technology and your requirements advance.

### Upgrades and enhanced features

The RigExpert MATCH analyzer offers a range of upgrades and enhanced features to expand its capabilities, ensuring it remains a valuable tool as your needs evolve. This section provides an overview of the available upgrades and step-by-step instructions for unlocking and using them.

### Key benefits of upgradeability

1. Enhanced capabilities:
  - Unlock advanced features and tools by upgrading your device with additional licenses.
  - Access functionalities such as higher frequency ranges, advanced measurement modes, and extended analysis tools.
2. Future-proof design:
  - Stay up-to-date with the latest advancements without needing to purchase a new device.
  - Upgradeable features ensure compatibility with emerging RF technologies.
3. Flexible licensing:
  - Start with the base model and expand to Advance and RFE licenses as your needs grow.

### How to upgrade

- Visit the RigExpert website and contact an authorized dealer to purchase desired upgrade License Pack.
- Follow the instructions provided with your License Pack to unlock new features on your device (page 12).

### Upgrades overview

MATCH supports a modular licensing system, allowing users to enhance the device by unlocking advanced features. Available upgrades include:

1. **Extended frequency ranges:**
  - Expand the analyzer's range from the Base **70 MHz to 230 MHz (Advanced license)** and **500 MHz (RFE license)**.
  - Ideal for working with higher frequency bands in advanced RF systems.
2. **Advanced measurement features:**
  - Unlock tools such as **Time Domain Reflectometry (TDR)** for cable fault detection and analysis.
  - Enable **Smith Chart visualization** for impedance matching and analysis.
3. **Additional analysis modes:**
  - Access enhanced modes like **Multiband Mode**, **MultisWR**, and **SWR2Air** with select upgrades.

See full Licences comparison table Annex 1 (page 12).

### Where to buy a License Pack

Please visit the RigExpert webpage [rigexpert.com](http://rigexpert.com) and find the list of partners that are selling MATCH licenses all over the world.

Find the best price and delivery option and make an order. After you get your License Pack follow the instructions below to upgrade your MATCH.

### Step-by-step instructions for upgrading your MATCH analyzer

Please visit the RigExpert webpage [rigexpert.com](http://rigexpert.com) and find the list of partners that are selling MATCH licenses all over the world.

Find the best price and delivery option and make an order. After you get your License Pack follow the instructions below to upgrade your MATCH.

The MATCH license upgrade is available via Antscope2 software <https://rigexpert.com/software/antscope2/>.

The free AntScope2 software is designed to support various models of RigExpert antenna analyzers on your Windows or Mac computer.

Follow these detailed steps to successfully upgrade your RigExpert MATCH analyzer and unlock its enhanced features:

### 1. Download and install AntScope2 software

- Visit the official RigExpert website **Support page/ Downloads**.
- Download the **AntScope2** software for your PC.
- Follow the on-screen instructions to complete the installation.

*License upgrades and registration are done via the Internet. Please make sure your PC is connected to the Internet.*

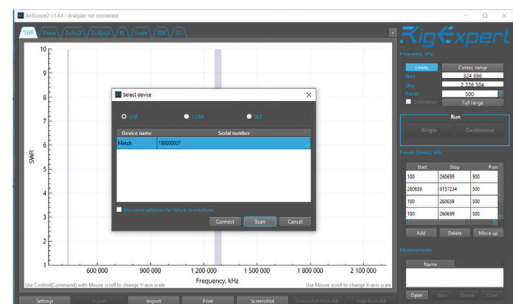
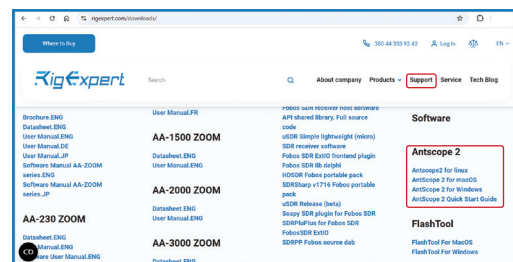

## 2. Run AntScope2 and register the application (recommended)

- Launch **AntScope2** on your PC.
- Navigate to **Settings** and select **Register Application**.
- Confirm by clicking **Yes**, then enter your name and email address.
- Check your email inbox for a confirmation link and follow it to complete the registration process.

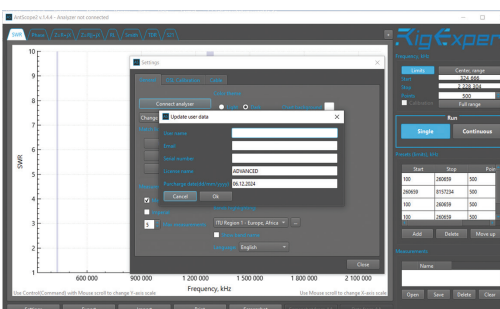
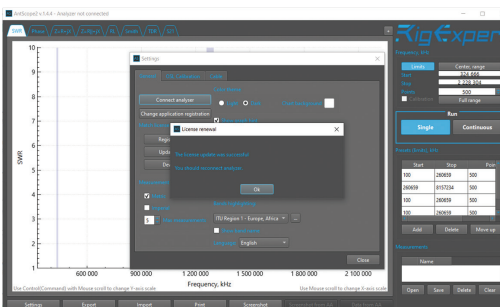
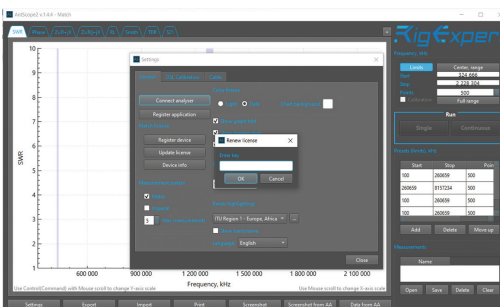
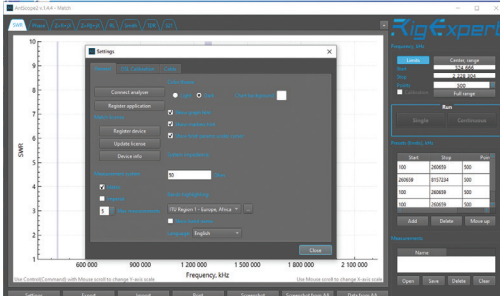

## 3. Connect your MATCH analyzer to the PC

- Use a **USB Type-C cable** to connect your MATCH analyzer to your PC.
- Ensure a secure connection, and avoid disconnecting during the upgrade process.

## 4. Open AntScope2

- Launch the **AntScope2** application on your PC.

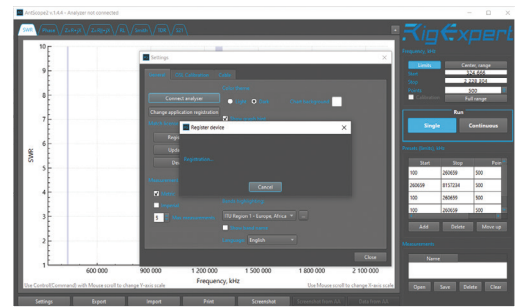

## 5. Connect to your analyzer in AntScope2

- In the **AntScope2** application, go to **Settings** and select **Connect Analyzer**.
- In the pop-up window, select your **MATCH** analyzer from the list and click **Connect**.

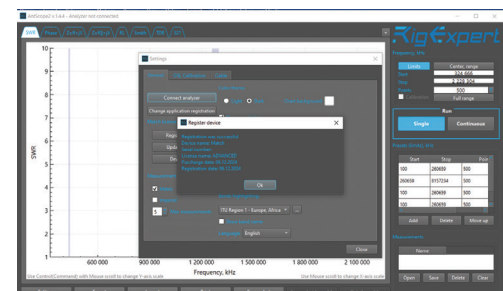

## 6. Register your MATCH analyzer (recommended)

- Navigate to **Settings** in AntScope2 and select **Register Device**.
- Enter your name, email address, and purchase information.
- Click **OK** to confirm. Once you see the message **Registration was successful**, your device registration is complete.
- Device registration unlocks extended support and additional benefits through the RigExpert Club.

## 7. Start the license upgrade

- Go to the **Settings** menu in AntScope2 and select **Update license**.

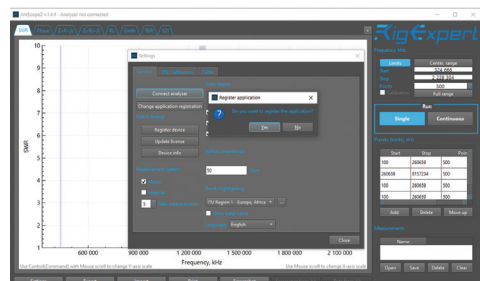

## 8. Enter your 12-digit License Key

- When prompted, enter the **12-digit License Key** provided in your License Pack.
- Click **OK** to confirm.

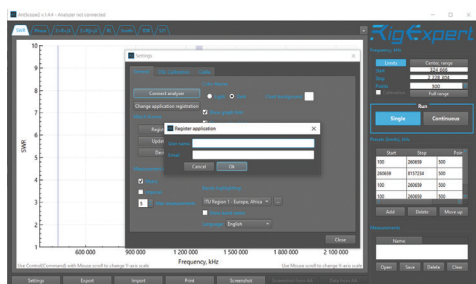

## 9. Successful upgrade confirmation

- A message will appear on your PC stating that the **license update was successful**.
- Your MATCH analyzer is now upgraded with the new features.

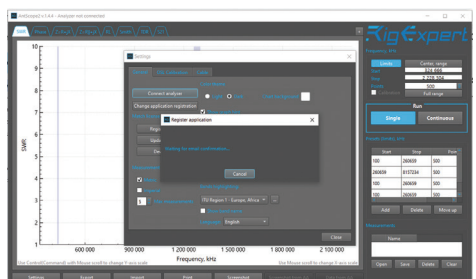

## 10. Reconnect Your Device

- Return to **Settings**, select **Connect Analyzer**, and reconnect your MATCH analyzer to the PC.

## 11. Verify the Upgrade

- On your MATCH analyzer:  
Navigate to the **Main Menu**, select **Info**, and check the license type.
- In AntScope2:  
Go to **Settings** and select Device Info to view the upgraded license details.

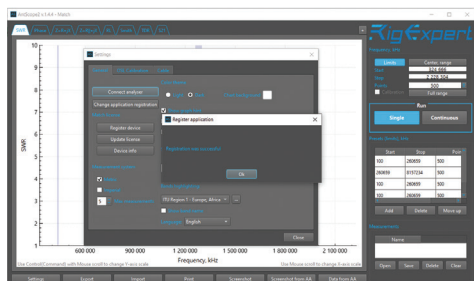

## Maintenance and care

Proper maintenance and care for your RigExpert MATCH analyzer ensures reliable operation, longevity, and optimal performance. The device comes pre-calibrated for immediate use.

### Battery care

#### 1. Charging:

- Charge the built-in Li-Ion ICR18650 battery using a USB Type-C cable.
- Ensure the battery is charged at a temperature range of 0°C to 40°C.

#### 2. Battery life:

- Fully charge the battery before extended use.
- Do not allow the battery to fully discharge regularly, as this can reduce its lifespan.

#### 3. Replacement:

- Use only the specified ICR18650 (2600mAh) battery when replacement is required.
- For battery replacement, contact an authorized service center to ensure proper handling and compatibility.

### Calibration

#### Device calibration:

- RigExpert MATCH analyzer is pre-calibrated at the factory for accuracy.
- Regular recalibration is not required under normal operating conditions.
- If recalibration becomes necessary, follow the instructions in this manual or contact an authorized service center.

### Cleaning and handling

#### Exterior cleaning:

- Use a soft, dry cloth to clean the device.
- Avoid using water, solvents, or abrasive materials.

#### Safe handling:

- Handle the device with care to prevent impacts or damage to internal components.
- Ensure all connectors and ports remain free of dust and debris.

### Storage

#### Storage conditions:

- Store the device in a dry, cool place within the temperature range of **-20°C to +60°C (-4°F to 140°F)**.
- Ensure the battery is charged to at least 50% before long-term storage.

#### Moisture protection:

- Avoid storing the analyzer in damp or humid environments to prevent damage.

### Firmware Updates

#### Stay Updated:

- Check the RigExpert website for firmware updates to ensure the device has the latest features and fixes.
- Use to easily download and install firmware updates.

#### FlashTool

<https://rigexpert.com/files/software/FlashTool/FlashToolForMacOS/>  
<https://rigexpert.com/files/software/FlashTool/FlashToolForWindows/>

### When to Seek Support

- If the battery shows signs of damage or wear, or if the device behaves unexpectedly, contact RigExpert customer support.
- For recalibration or repairs, rely on authorized service centers to ensure your analyzer remains in peak condition.

RigExpertCare™ is a 2-year limited warranty coverage: Rig Expert Ukraine Ltd. will replace defective goods covered by the Warranty with new goods of the same model as soon as possible. Get one more additional year of warranty with RigExpert Club by registering a MATCH device (see page 10).

## Annex 1

### Licenses comparison table

Functionality	Licenses		
	Base	Advanced	RFE
Frequency limits	70 MHz	230 MHz	500 MHz
<b>Chart modes</b>			
SWR Chart	✓	✓	✓
RX Chart	✓	✓	✓
Return Loss Chart	✓	✓	✓
Smith Chart		✓	✓
TDR Chart			✓
<b>Table modes</b>			
SWR Meter	✓	✓	✓
MultiSWR Meter	✓	✓	✓
R, X, Z, L, C, Loss Meter	✓	✓	✓
Multé		✓	✓
MultiBand		✓	✓
Quick band		✓	✓
<b>Tools</b>			
Stub Tuner		✓	✓
Length vs VF		✓	✓
Cable Loss		✓	✓
Cable Impedance		✓	✓
Self Tests	✓	✓	✓
OSL Calibration		✓	✓
User OSL Calibration Profiles		✓	✓
LC meter			✓
<b>Features</b>			
SWR2Air feature		✓	✓
BLE Feature		✓	✓
Memory Slots for saving measurements	✓	✓	✓
Jump to Extremum Value	✓	✓	✓
Save Measurements	✓	✓	✓
Load Measurements	✓	✓	✓
Choosing GUI Language	✓	✓	✓
Choosing GUI Palette	✓	✓	✓
Choosing Battery Profile	✓	✓	✓
Controlling Sound	✓	✓	✓
Selecting System Impedance	✓	✓	✓
Choosing Metric/Imperial Units	✓	✓	✓
Choosing ITU Regions	✓	✓	✓
Setting the Cable Velocity Factor	✓	✓	✓
Screen Brightness	✓	✓	✓
Factory Reset	✓	✓	✓
Clearing Saved Charts	✓	✓	✓
<b>Languages</b>			
English	✓	✓	✓
Ukrainian	✓	✓	✓
Spain	✓	✓	✓
French	✓	✓	✓
German	✓	✓	✓
Portuguese	✓	✓	✓
Italian	✓	✓	✓

## Precautions



Never connect the analyzer to your antenna in thunderstorms. Lightning strikes as well as static discharge may kill the operator.



Never leave the analyzer connected to your antenna after you finish operating it. Occasional lightning strikes or nearby transmitters may permanently damage it.



Never inject RF signal or DC voltage into the antenna connector of the analyzer. Do not connect it to your antenna if you have active transmitters nearby.



Avoid static discharge while connecting a cable to the analyzer. It is recommended to ground the cable before connecting it.



Do not leave the analyzer in active measurement mode when you are not actually using it. This may cause interference to nearby receivers. If using a personal computer, first connect the cable to the antenna connector of the analyzer, then plug the analyzer into the computer USB port. This will protect the analyzer from static discharges.

## Annex 3

### Tools menu

The **Tools menu** provides access to advanced measurement modes and utilities to enhance the functionality of your RigExpert MATCH analyzer. These tools help in specialized tasks such as tuning stubs, calculating cable parameters, measuring components, and verifying the device's performance.

### Quick Access

Press the **(F) + (8) (TOOLS)** key combination to open the **Tools Menu** quickly.

### Available Tools

#### Multiband mode

The mode provides up to 3 overlapped charts of selected bands. In-band values are shown as curves, minimal SWR of the band, and frequency at this point provided by the text. Measuring is done in a continuous "in loop" manner, providing a conveniently "alive" picture.

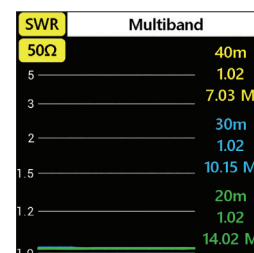

Use **(▲)** and **(▼)** to choose a group, press the **(3)** and the band for the curve. Use the **(OK)** button to start and stop measuring.

## Stub Tuner

- **Purpose:** Helps create or check  $1/4\lambda$  (quarter-wave) or  $1/2\lambda$  (half-wave) coaxial stubs.
- **How to Use:**
  1. Connect an open or short-circuited cable to the analyzer.
  2. Press the **OK** key to begin.
  3. The analyzer will display the resonant frequencies for quarter-wave and half-wave stubs.
- **Note:** Longer cables have lower resonant frequencies.

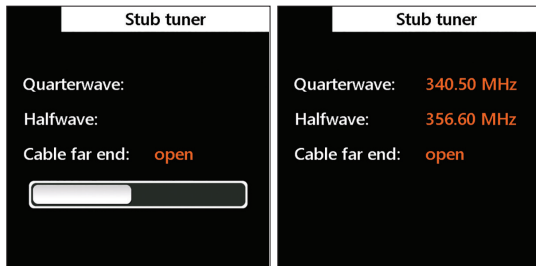

## Length & VF

Knowing the velocity factor, the physical length of a cable can be easily calculated. Press the **▲** button and enter the value of the velocity factor or cable length, then press **OK** to start measurement.

To find the velocity factor of an unknown cable, press the **▼** key and enter the physical length, then press **OK**.

The velocity factor depends on the type of transmission line.

For instance, RG-58 cable with polyethylene insulator has VF=0.66

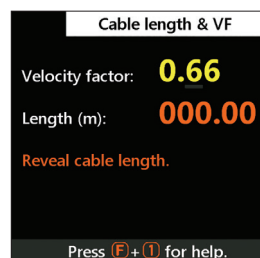

## Cable loss

The whole measure range is divided into subranges with convenient frequency steps. The measure is done in a two-stage operation. Change of subrange is only possible at 1 stage and requires full cycle measurement.

Use the **3** key to set the required subrange, then follow on-screen instructions to perform the two-stage measurement.

Once the analyzer finishes the measurement, you will see the Loss versus frequency chart. Use the **◀** (Left) and **▶** (Right) cursor keys to change frequency and watch the loss value in decibels at the bottom of the analyzer's screen.

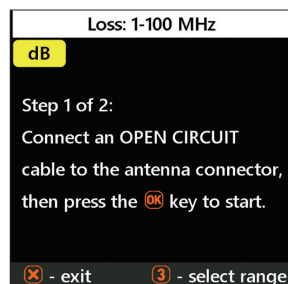

## Cable impedance

To measure the characteristic impedance, use a piece of an open-circuited cable: half of a meter (or a foot) or longer should be fine. Press **OK** to start.

Next, the far end of the cable should be short-circuited. Press **OK** to continue. There are several reasons why the resulting chart does not look smooth, so we need to use the **◀** (Left) and **▶** (Right) cursor keys to find the location where the impedance is stable.

The result is shown at the bottom left corner of the screen.

Use **F** + **▲** (Up) and **F** + **▼** (Down) key combinations to change the scale, if needed.

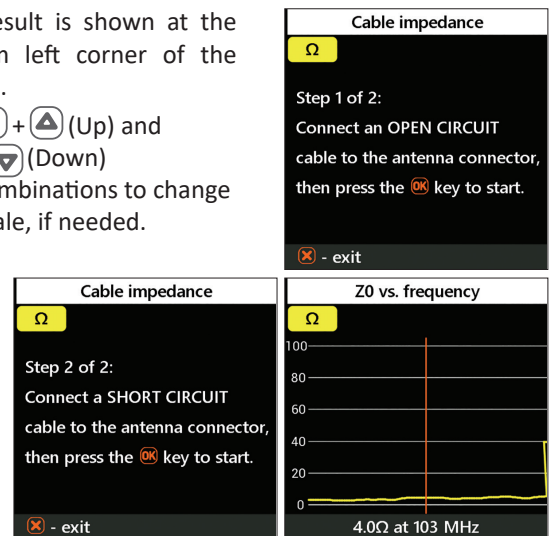

## LC meter (available for RFE license)

Use **3** to choose one of six modes (Inductance L, Q, tan  $\delta$  and Capacitance C, Q, tan  $\delta$ ), press **▶** to start measure, evaluate the result, tune the range to the most reliable values, and restart the measure, if required.

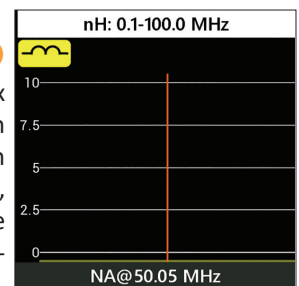

Be aware of many factors that will impact the result of the measure -stray capacitance and inductance, non-uniformities of element connection, and more complex behavior of components at higher frequency.

Avoid picking values at series and parallel resonances (reactance change sign) and adjacent areas, and avoid fast-changing slopes. Pick values from more stable, persistent areas of the chart. In most cases, measures at lower frequencies are more reliable.

## Self-tests

There are several built-in self-tests in the Match analyzer, which can be run by the user to make sure the analyzer is working properly. Press **▶** to start the test and then follow the instructions given on the display.

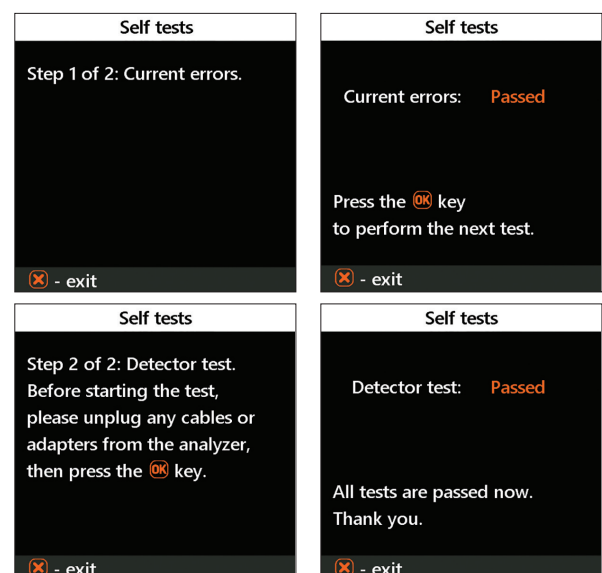

## Settings menu

The **Settings menu** allows you to configure various options to customize and optimize your RigExpert MATCH analyzer for your specific needs.

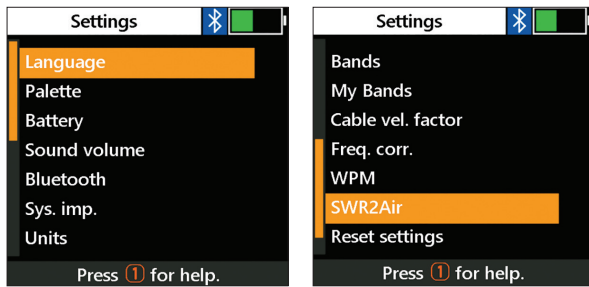

### Quick Access

To quickly open the Settings Menu, press the **(F) + (1) (SETTINGS)** key combination.

### Available Settings

- 1. Language:**  
Select the desired language for the analyzer's menus.
- 2. Palette:**  
Choose a color scheme for the display to enhance visibility.
- 3. Battery:**  
Select a power consumption mode to optimize battery life or performance.
- 4. Sound volume:**  
Adjust the sound volume of the analyzer.
- 5. Bluetooth:**  
Turn Bluetooth functionality on or off as required.
- 6. System impedance (sys. Imp.):**  
Select the system impedance (25, 50, 75, 100, 150, 200, 300, 450, or 600 Ohms) to ensure accurate SWR and return loss readings.
- 7. Units:**  
Choose between metric (meters) or imperial (feet) for distance measurements.
- 8. Bands:**  
Select a regional standard for highlighting amateur radio bands.
- 9. Cable velocity factor (available for RFE license):**  
Set the velocity factor of the coaxial cable for precise TDR mode measurements.
- 10. Frequency correction (Freq. Corr.):**  
Calibrate the analyzer's oscillator to improve frequency measurement accuracy.
- 11. WPM (available for Advanced and RFE licenses):**  
Adjust the Words Per Minute rate for Morse code output in SWR2Air mode.
- 12. SWR2Air (available for Advanced and RFE licenses):**  
Configure the mode of operation for the SWR2Air feature.
- 13. Reset Settings:**  
Restore all settings to factory defaults.
- 14. Clear Saved Charts:**  
Delete all stored charts and clear memory slots.

## Tips for Using the Settings Menu

- Make adjustments carefully to suit your specific requirements.
- Use the Reset Settings option as a quick way to troubleshoot issues by restoring default values.
- For advanced features like TDR mode, My Bands, or SWR2Air, ensure you have the appropriate license.

## TDR mode (available for RFE license)

### Theory

Time domain reflectometers (TDR) are electronic instruments used for locating faults in transmission lines. A short electrical pulse is sent over the line, and then a reflected pulse is observed. By knowing the delay between two pulses, the speed of light, and the cable velocity factor, the DTF (distance to fault) is calculated. The amplitude and the shape of the reflected pulse give the operator an idea about the nature of the fault. Instead of a short pulse, a "step" function may be sent over the cable.

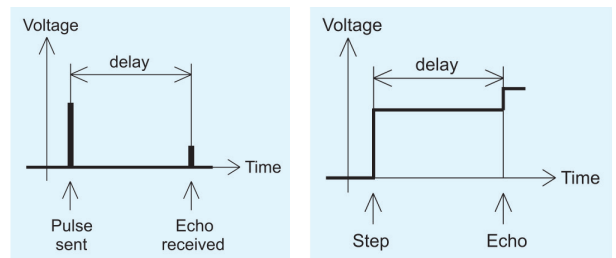

Unlike many other commercially available reflectometers, RigExpert MATCH does not send pulses into the cable. Instead, another technique is used. First, R and X (the real and the imaginary part of the impedance) are measured over the whole frequency range (up to 500 MHz). Then, the IFFT (Inverse Fast Fourier Transform) is applied to the data. As a result, impulse response and step response are calculated.

This method is often called a "Frequency Domain Reflectometry", but the "TDR" term is used in this document since all calculations are made internally and the user can only see the final result.

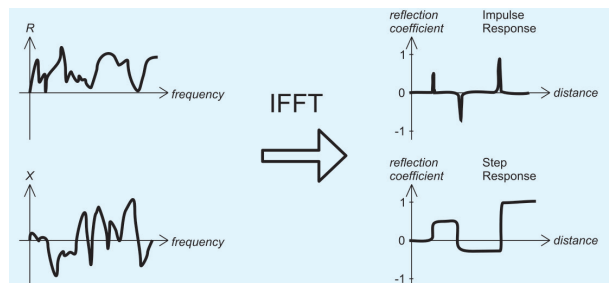

The vertical axis of the resulting chart displays the reflection coefficient:  $\Gamma = -1$  for short load, 0 for matched impedance load ( $Z_{Load} = Z_0$ ), or +1 for open load. By knowing the cable velocity factor, the horizontal axis is shown in the units of length. Single or multiple discontinuities can be displayed on these charts. While the Impulse Response chart is suitable for measuring distance, the Step Response chart helps in finding the cause of a fault. See the examples of typical Step Response charts on the page.

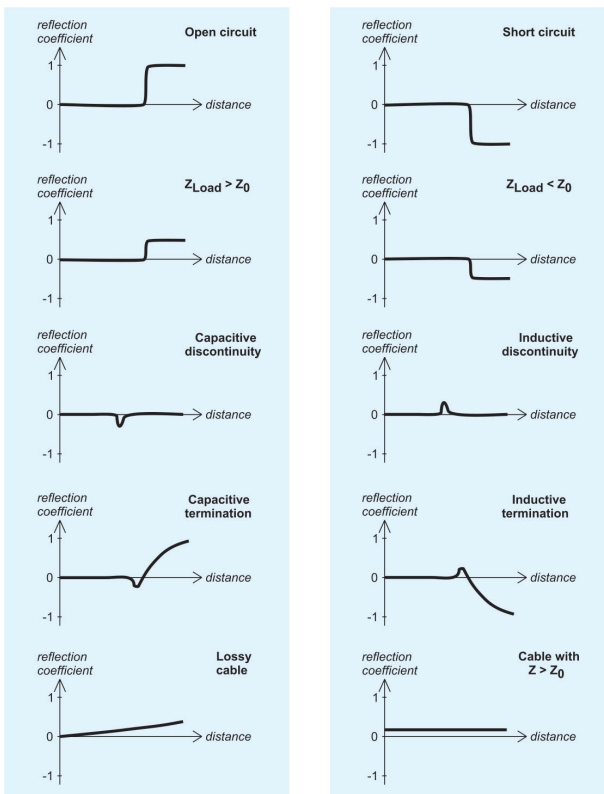

The standards used for calibration should be of high quality. This requirement is especially important for high frequencies (100 MHz and upper). Three different calibration standards should be used: an “open”, a “short” and a “load” (50 Ohm OSL kit). A place where these standards are connected during calibration is called a reference plane. If the calibration is done at the far end of a transmission line, parameters of this line will be subtracted from measurement results and the analyzer will display “true” parameters of a load.

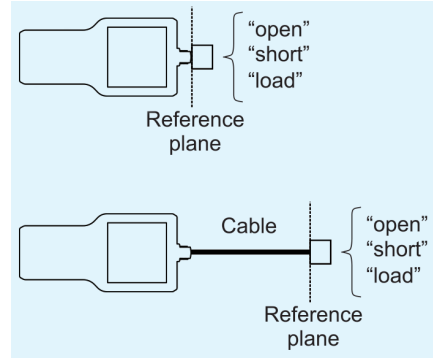

**Practice**

**Quick Access**

To quickly open the Settings Menu, press the **(F) + (8) (SETTINGS)** key combination.

Use **(3)** for a quick setup popup, choose the smallest range appropriate for your cable length (shorter distances have better length resolution), and tune the velocity factor fast. Change of velocity factor corrects range distances.

The result of the measure can be viewed in three modes: impulse response, step response, and impedance response.

To switch view press **(F) + (3)**, and use **(0)** for the numerical representation of all data at the marker. Three pictures there show real measures of short open stubs in different view modes. Explore built-in help for other button functionality.

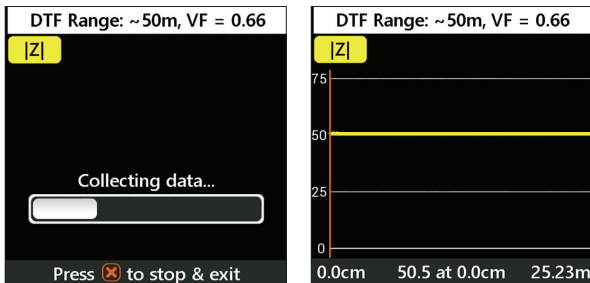

Choose Calibration from the Main Menu.

Key **(▶)** starts the calibration sequence for the selected profile. Follow the instructions on the screen to perform 3 steps of calibration and press **(OK)**.

You may connect calibration standards to the far end of a cable, so the cable will be “nulled”.

**Annex 6**

**Calibration**

RigExpert Match is designed for high performance and uses factory open short-load (OSL) calibration.

For the RFE license, there are 10 user OSL profiles, that can be applied above factory OSL to make usage more flexible for experienced users.

Use **(F) + (2)** in the main menu to go to the calibration profiles management screen.

Select the profile and press **(OK)** to make the profile active, a combination of **(F) + (6)** allows you to edit the existing profile name.

To apply calibration, press the **(F) + (2)** key combination in any measurement mode. The small “CALn” mark will appear on the n screen, where n the s number of active profiles le(0..9)

### Dummy loads



Amphenol 202109-10  
1 Watt terminator plug.  
**Low SWR.**

50 Ohm dummy loads are not all equal.  
For calibration please use low-power RF terminators which provide low SWR over the wide frequency range. High-power terminators, with cable or not suitable for calibration purposes.

### For private households: Information on Disposal for Users of WEEE



This symbol on the product (and/or accompanying documents) means that used electrical and electronic equipment (WEEE) should not be mixed with general household waste. For proper treatment, recovery, and recycling, please take this product(s) to designated collection points where it will be accepted free of charge.

Alternatively, in some countries, you may be able to return your products to your local retailer upon purchase of an equivalent new product. Disposing of this product correctly will help save valuable resources and prevent any potential negative effects on human health and the environment, which could otherwise arise from inappropriate waste handling.

Please contact your local authority for further details of your nearest designated collection point. Penalties may be applicable for incorrect disposal of this waste by your national legislation.

### For professional users in the European Union

If you wish to discard electrical and electronic equipment (EEE), please contact your dealer or supplier for further information.

### For disposal in countries outside of the European Union

This symbol is only valid in the European Union (EU). If you wish to discard this product, please contact your local authorities or dealer and ask for the correct method of disposal.

## Contacts - RigExpert

### rigexpert.com

RigExpert Ukraine Ltd. is headquartered in Kyiv, Ukraine.  
The office is located at Solom'yans'ka Square, 2, 03035, Kyiv, Ukraine.

You can reach us by phone at +380 (44) 353 92 42 or via email at [office@rigexpert.com](mailto:office@rigexpert.com).

For support and warranty services,  
**contact [support@rigexpert.com](mailto:support@rigexpert.com).**

For partnership inquiries,  
**email [office@rigexpert.com](mailto:office@rigexpert.com).**

If you're interested in purchasing RigExpert products,  
it's recommended to contact your nearest dealer.  
You can find a list of authorized dealers on our website.

For service or warranty issues, RigExpert has service centers worldwide.  
For more detailed information or specific inquiries, please visit RigExpert's official website.